

REV.	DESCRIPTION	APPROVED BY	DATE	ECN NO.
A				
B				
C				

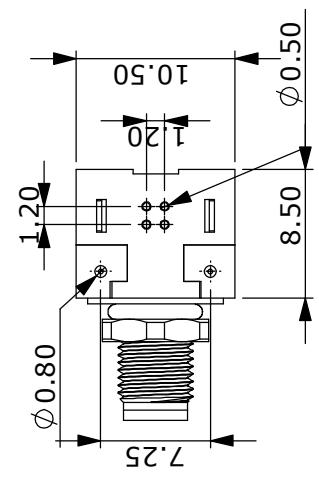

**M5x0.5**

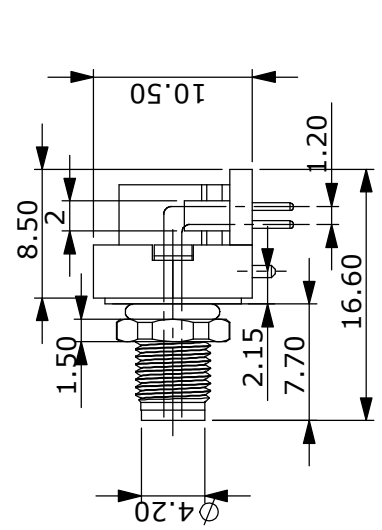
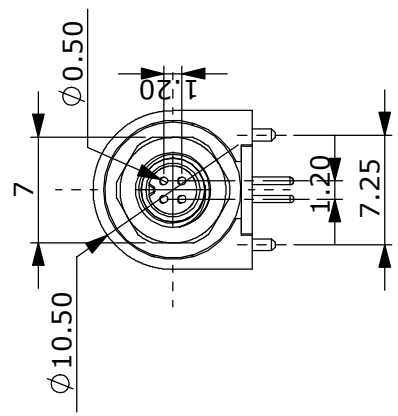
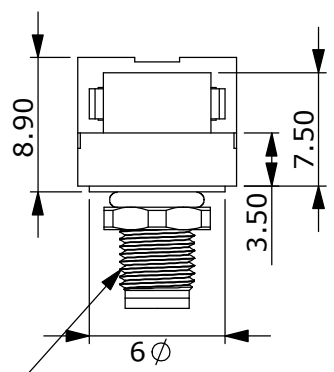
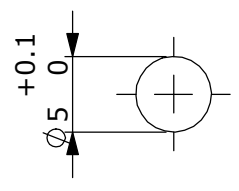

**PANEL CUT-OUT**

**PCB LAYOUT**

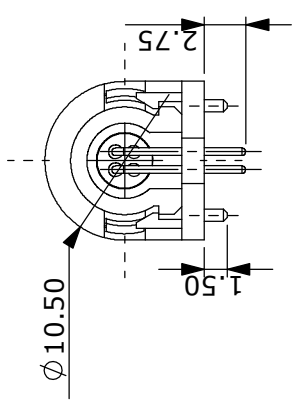
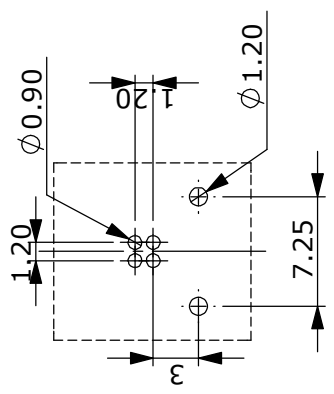

No.	Description	Material	Treat	Q'ty
1	Back Shell	PBT		1
2	Back Base	PBT		1
3	Shield	Brass	Nickel Ptd.	1
4	Housing	PBT		1
5	Glue	Epoxy		1
6	Terminals1	Brass	Gold Ptd.	2
7	Terminals	Brass	Gold Ptd.	2
8	O-Ring	NBR		1
9	Screw Nut	Brass	Nickel Ptd.	1

DRAWN	NEIL	APP'D	KUNG	UNIT	mm	TOLERANCE	x ±0.20 .xx ±0.10 .xxx ±0.05 .xxxx ±0.03 ANGULA ±1°		JKL TECHNOLOGY CO., LTD.			SHEET	1
	CHK'D								TIM	PART NO.			