

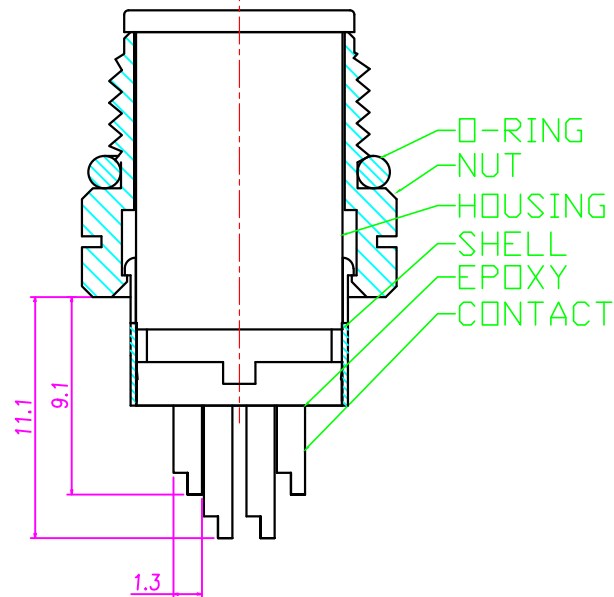

REV.	DESCRIPTION	APPROVED BY	DATE	ECN NO.
A	RELEASE	Fido Weng	25/06/12'	
B				
C				

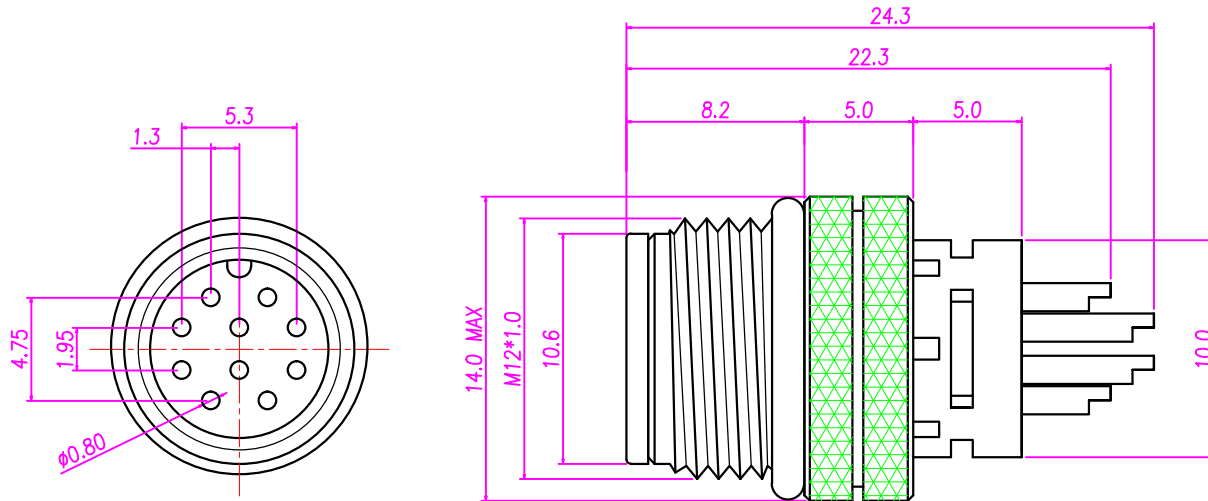

1. MATERIAL :
 - 1-1. HOUSING : PBT UL94V-0 ; COLOR : BLACK
 - 1-2. CONTACT : BRASS
 - 1-3. NUT : BRASS
 - 1-4. O-RING : EDPM
 - 1-5. SHELL : BRASS
 - 1-6. EPOXY Base :EF400A&EF400B.COLOR:BLACK
2. FINISH :
 - 2-1. CONTACT : 10 MICRO INCHES MIN. GOLD PLATED
UNDER PLATE : NICKEL
 - 2-2. NUT : NICKEL PLATED
 - 2-3. SHELL : BRIGHT TIN
3. ELECTRICAL SPECIFICATION :
 - 3-1. Rated current : 1A
 - 3-2. Rated Voltage : 30V
 - 3-3. Water proof: IPX7
4. Environmental :
 - 4-1. Operation Temperature : -40℃~85℃

DRAWN	Ku Chou	APP'D	Fido Weng	UNIT	mm	TOLERANCE		TITLE	M12 10PIN (M)WATERPROOF SHIELDED TYPE.			SHEET
CHK'D	Emily Suen			SCALE	1:1	.x ±0.20 .xx ±0.10 .xxx ±0.05 .xxxx ±0.01 ANGULA ±1°		JKL TECHNOLOGY CO., LTD.	PART NO.	WP-10M2-09	DWG NO.	QC5795