

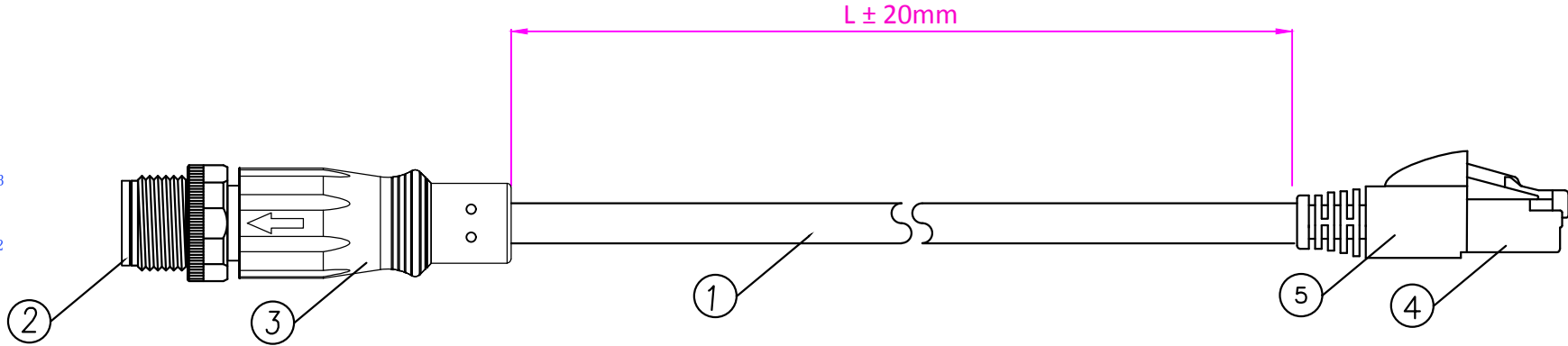

REV.	DESCRIPTION	APPROVED BY	DATE	ECN NO.
A	RELEASE	KUNG	22/04/15	
B				
C				

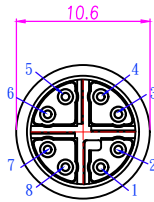

ELECTRICAL TEST:

<1>100% OPEN SHORT&MISS WIRE TEST

<2>CONTACT RESISTANCE : 2 ohm<MAX>.

<3>INSULATION RESISTANCE:DC 200V 10ms 5M ohm(MIN).

5	RJ45 BOOT ,BLACK OR GREY	1
4	CAT.6A FTP PLUG, 50u" (PK 612 88 MS-2E4.9)	1
3	OVERMOLD : PVC ; COLOR : BLACK OR GREY	1
2	M12 8P MALE X-CODE CABLE SOLDER TYPE.	1
1	26AWGX4P, CAT.6A FTP , GREY	1
ITEM	DESCRIPTION	Q'TY

WIRING DIAGRAM (T568B)

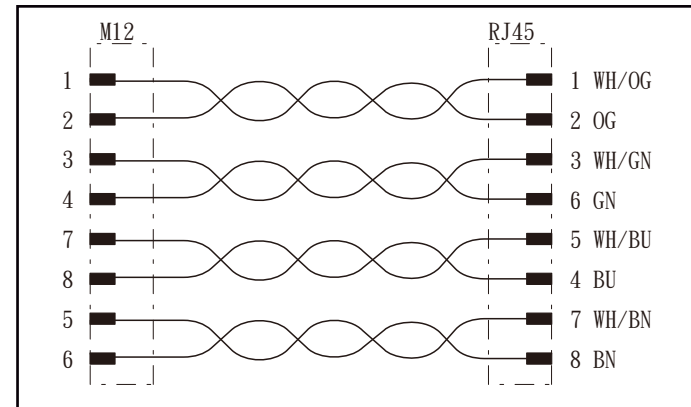

DRAWN	KU	APPEND	KUNG	UNIT	mm	TOLERANCE	
CHOKED				SCALE	1:1	.x ±0.20 .xx ±0.10 .xxx ±0.05 .xxxx ±0.03 ANGULA ±1'	

JKL TECHNOLOGY CO., LTD.

TITLE	M12 8P X-CODE /RJ45 CABLE ASS'Y.	SHEET	1
PART NO.	WP-08M2-XM-GY	DWG NO.	WP-08M2-43-11
			VERSION A